



# SB16

# SHOEBOX LIGHT

Project: \_\_\_\_\_ Type: \_\_\_\_\_

Name: \_\_\_\_\_ Date: \_\_\_\_\_



Watts	150W	300W	450W
CCT	3000K-4000K-5000K	CCT: 3000K-4000K-5000K; Single: 5700K	5700K
Size	See Dimensions	Lumens	20,250-21,750lm 44,000-44,820lm 58,500-65,250lm
Voltage	120-277V 277-480V	IP Rating	IP65
Dimming	0-10V	Materials	Die-Cast Aluminum
Beam Angle	155*90° Type III	Finish	Bronze (available in white)
CRI	>80	Lens	Clear
PF	≥ 0.9	Lifespan	50,000 Hours

## OVERVIEW

- CCT:** Tunable, 5700K
- Applications:** IP65
- Efficacy:** 135-155lm/W
- Dimming:** 0-10V
- LED Type:** Lumileds 2835
- Lens Type:** Clear
- Operating Temp:** -13°F to 113°F
- Operating Humidity:** 5% - 95% RH
- Lifespan:** 50,000 Hours
- Warranty:** 5 Years

## FEATURES

- 10KV Surge Protector pre-installed
- Five Mounting Options: Slip Fitter, Extruded Mount, Yoke Mount, Large-C Mount, Universal Bracket
- Optional Accessories: Photocell, Surge protector, Shield, Motion Sensor

SARIN LED Shoebox Lights are commonly used to replace high-pressure sodium and metal halide lights to provide energy savings of up to 70%. These area lights are safe for outdoor use and are protected from rain, snow, and weak jets of water, such as sprinklers.

Shoebox Lights are perfect for stadiums, parks, billboards, parking lots, and office buildings. An optional photocell sensor allows the light to automatically activate at night. This fixture turns on and off instantly without flickering or humming. The lens has a glare-reduction composition that softens the light and makes it more uniform and safe to the eye. This Dark Sky compliant light eliminates glare and prevents light pollution.

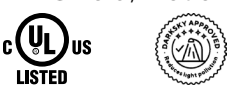



SB16

SHOEBOX  
LIGHT

Project: \_\_\_\_\_ Type: \_\_\_\_\_

Name: \_\_\_\_\_ Date: \_\_\_\_\_

### PHOTOMETRICS:

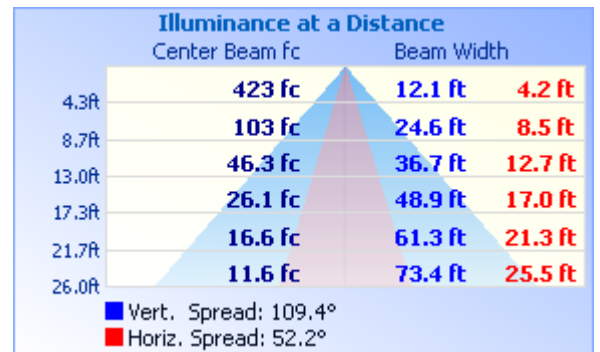
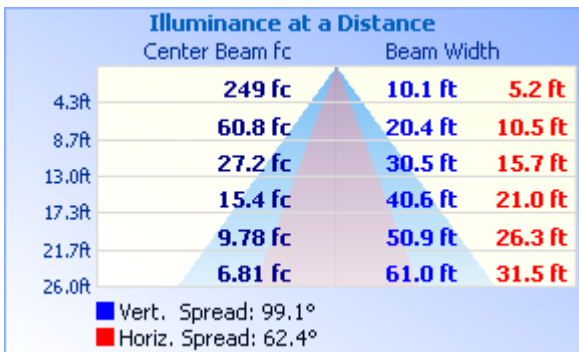
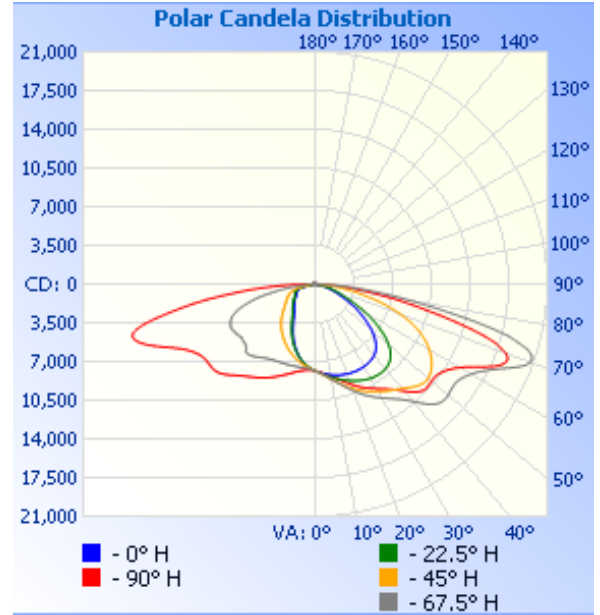
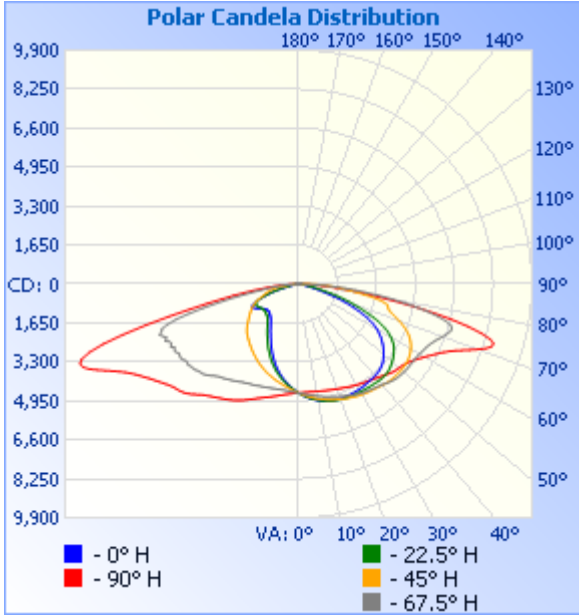



SB16

SHOEBOX  
LIGHT

Project: \_\_\_\_\_ Type: \_\_\_\_\_

Name: \_\_\_\_\_ Date: \_\_\_\_\_

### DIMENSIONS:

150W

Adjustable Mount

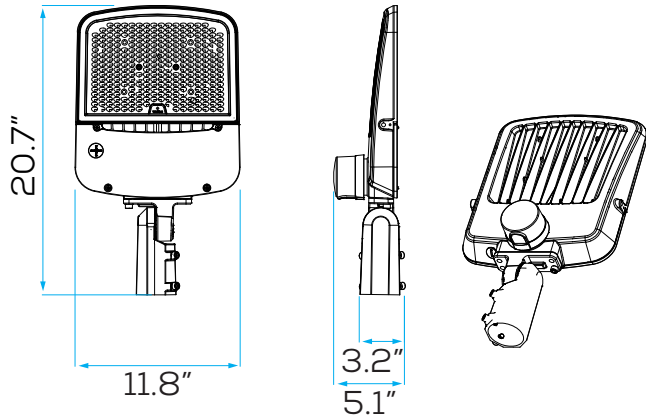

2-in-1 Mount

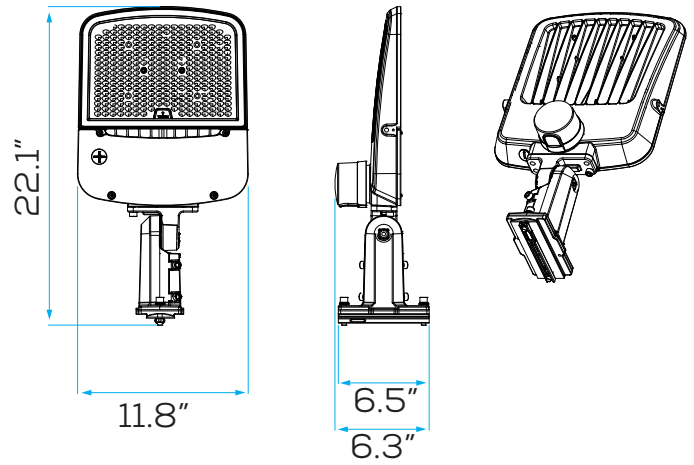

Yoke Mount

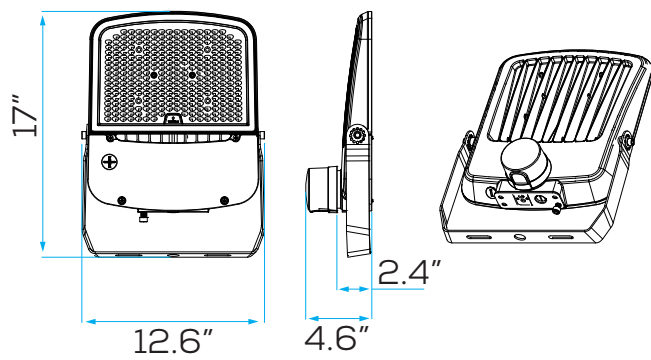

Extruded Arm

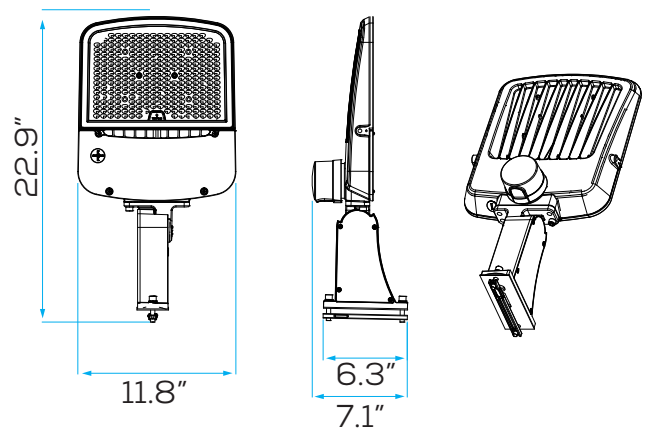



SB16

SHOEBOX LIGHT

Project: \_\_\_\_\_ Type: \_\_\_\_\_

Name: \_\_\_\_\_ Date: \_\_\_\_\_

### DIMENSIONS:

300W

Adjustable Mount

2-in-1 Mount

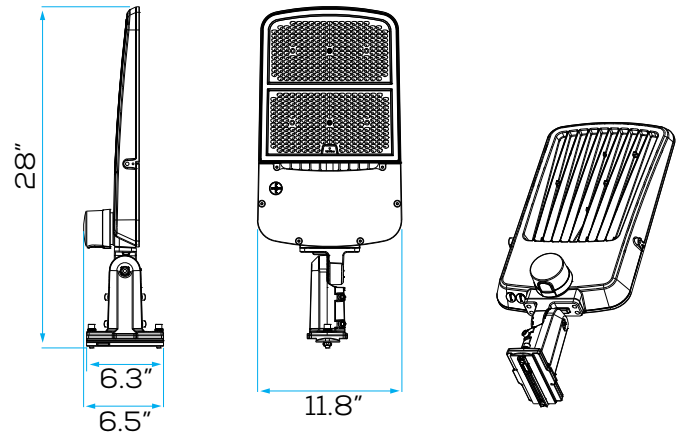
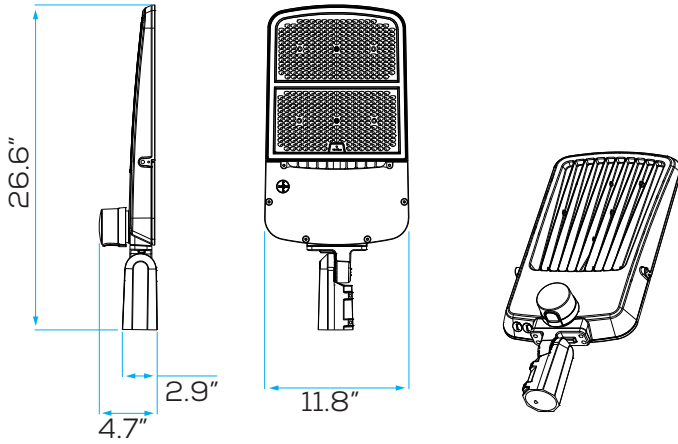

Yoke Mount

Extruded Mount

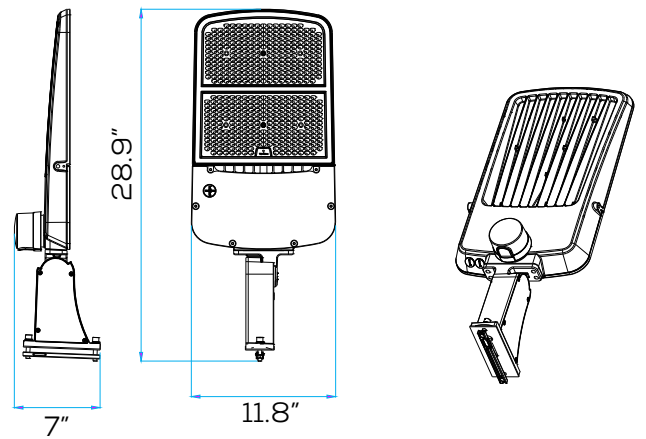
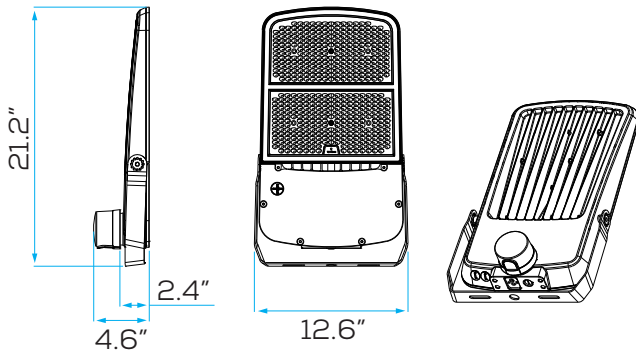



# SB16

# SHOEBOX LIGHT

Project: \_\_\_\_\_ Type: \_\_\_\_\_

Name: \_\_\_\_\_ Date: \_\_\_\_\_

## ORDER FORM:

(\*) Special Order/Not Commonly Stocked

Custom Model Assembly

	<b>Fixture</b>	<b>CCT</b>	<b>Watts</b>	<b>Beam Angle</b>	<b>Voltage</b>
	<input checked="" type="checkbox"/> SB16	<input type="checkbox"/> Tunable	<input type="checkbox"/> 150W	<input checked="" type="checkbox"/> Type III	<input type="checkbox"/> 120-277V
<u>SES-SB16-CCT-150W</u> Example Model Number		<input type="checkbox"/> 5700K	<input type="checkbox"/> 300W		<input type="checkbox"/> 277-480V

**SES – SB16 – – – Type III –**

<b>Quantity</b>	Fixture	CCT	Watts	Beam Angle	Voltage
-----------------	---------	-----	-------	------------	---------

### Common Stock Models:

### Optional Accessories:

Item #	Model #
11324	SES-SB16-CCT-150W
11325	SES-SB16-CCT-300W
11326	SES-SB16-5700-300W
11327	SES-SB16-5700-300W-480V
11369	SES-SB16-5700-450
11353	SES-SB16-5700-300W-WH

Item #	Model #	QTY:
10899	JL-205C-PHOTOCELL	
11325-A	SES-SB16&SB14-SLIP-FITTER-BRONZE	
11325-B	SES-SB16&SB14-EXTRUDED-BRONZE	
11325-C	SES-SB16&SB14-SLIP-FITTER-WHITE	
11325-D	SES-SB16&SB14-EXTRUDED-WHITE	
11325-E	SES-SB16-150W-LARGE-YOKE-BRONZE	
11325-F	SES-SB16-300W-LARGE-YOKE-BRONZE	
11325-I	SB16-TYPE4-150W-LENS	
11325-J	SB16-TYPE5-150W-LENS	
11325-K	SB16-TYPE4-300W-LENS	
11325-L	SB16-TYPE5-300W-LENS	
11370	SES-SB16-BRACKET	



Slip Fitter



Extruded Arm



Large Yoke



Photocell